

Blank Flange Stainless Steel 304L

INFICON CF quality fittings are manufactured according to ISO 3669 and the latest TS/ ISO 3669-2 standard. INFICON Ultra high vacuum fittings are designed for applications down to 1×10^{-12} mbar and bakeout temperatures up to 400°C.

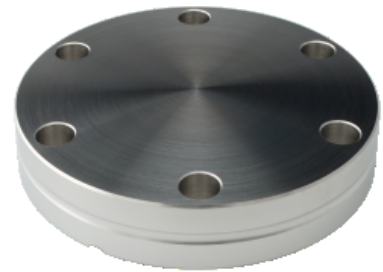

BENEFITS

- World wide logistics
- Design and measures follow strictly international respected standards
- Surface finish, welds, material specifications and cleanliness meet or exceed high vacuum specifications
- 2011/65/EU RoHS compliant

ORDER INFORMATION

Type	DN 16 CF	DN 40 CF	DN 63 CF	DN 100 CF	DN 160 CF	DN 200 CF
Blanking flange DN 63 CF-F			213-003			
Blanking flange DN 100 CF-F				213-004		
Blanking flange DN 16 CF-F	213-001					
Blanking flange DN 160 CF-F					213-005	
Blanking flange DN 200 CF-F						213-006
Blanking flange DN 250 CF-F						
Blind flange DN 40 CF-F		213-002				

DN 250 CF

213-007

SPECIFICATIONS

Type	DN 16 CF	DN 40 CF	DN 63 CF	DN 100 CF	DN 160 CF	DN 200 CF
Dimension A	7.5	13	17.5	20	22	24.5
Dimension B	14	38	66	104	155	205
Dimension C	1.4	1.4	1.4	1.4	1.4	1.4
Material:	Stainless steel 304L / 1.4306	Stainless steel 304L / 1.4306	Stainless steel 304L / 1.4306	Stainless steel 304L / 1.4306	Stainless steel 304L / 1.4306	Stainless steel 304L / 1.4306

DIMENSIONS

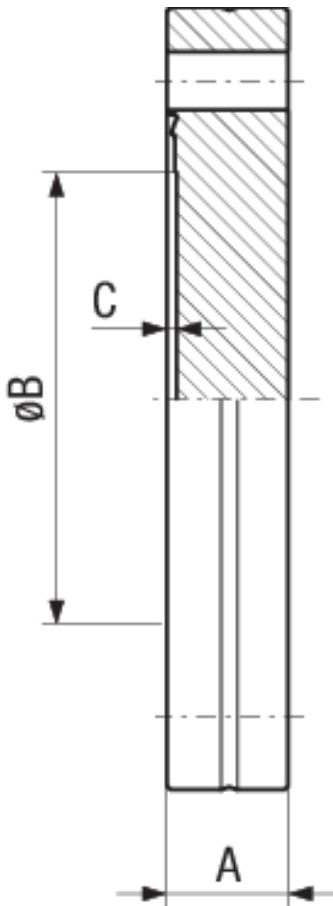

SPECIFICATIONS

Type	DN 250 CF
Dimension A	24.5
Dimension B	256
Dimension C	1.4
Material:	Stainless steel 304L / 1.4306



www.inficon.com reachus@inficon.com

Due to our continuing program of product improvements, specifications are subject to change without notice.
RateWatcher is a trademark of INFICON. All other trademarks are the property of their respective owners.

(2018-08) © 2018 INFICON